

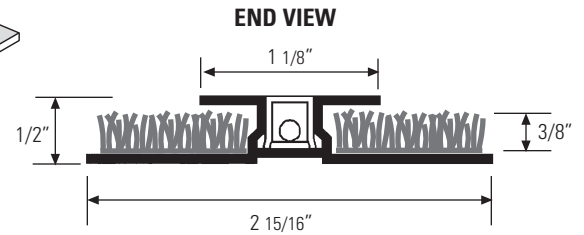

LF 700

**LAMPS INCLUDED
TRANSFORMER SOLD SEPARATELY**

- ADA compliant design
- Rated for extreme loads and heavy foot traffic
- Spillage resistant

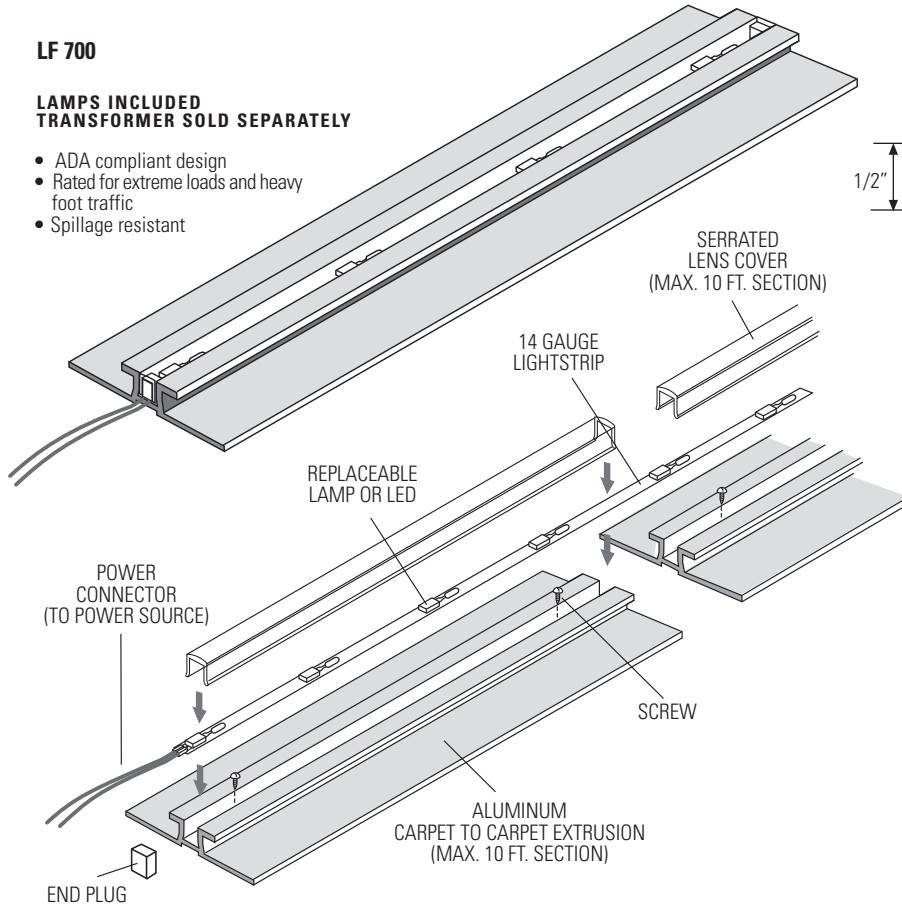

QUICK REFERENCE INSTALLATION INSTRUCTIONS

1. Screw mount extrusion sections.
2. Unroll lightstrip and lay into channel.
3. Strip end of lightstrip to attach power connector.
4. Insert end plugs at ends.
5. Snap in lens cover.
6. Connect to power source.

Do not exceed maximum run length per circuit. Extrusion, lens cover and lightstrip are available in pre-cut sections or can be field cut.

MAX. RUN PER CIRCUIT (5 AMPS)

| LAMP TYPE | LAMP SPACING | |
|-----------|--------------|---------|
| | 6" | 12" |
| LF 1 | 79 FT. | 158 FT. |
| LED | 112 FT. | 200 FT. |

CELESTIAL LED S & LAMPS ARE:

- Safe (low voltage)
- Energy efficient (low wattage)
- Rated for long life
- Run at optimum brightness for darkened areas
- Resistant to vibration from foot traffic
- Individually replaceable
- Dimmable from primary side of transformer

•DRAWING NOT TO SCALE•

S P E C I F I C A T I O N S

| PRODUCT CODE | EXTRUSION FINISH | LENS COLOR | | LED / LAMP | | LED / LAMP SPACING | |
|--------------|------------------|------------|-------|------------|--|--------------------|-------------------------------|
| | | | | TYPE | DESCRIPTION | | |
| LF 700 A | NATURAL ALUMINUM | C | CLEAR | A | DC9.5V 0.2 W AMBER LED (100,000 HRS. RATED LIFE) | 6 12 | 6" ON CENTER 12" ON CENTER |
| LF 700 B | ANODIZED BRONZE | A | AMBER | B | DC9.5V 0.2 W BLUE LED (25,000 HRS. RATED LIFE) | | |
| | | B | BLUE | G | DC9.5V 0.2 W GREEN LED (25,000 HRS. RATED LIFE) | | |
| | | G | GREEN | R | DC9.5V 0.2 W RED LED (100,000 HRS. RATED LIFE) | | |
| | | R | RED | W | DC9.5V 0.2 W WHITE LED (25,000 HRS. RATED LIFE) | | |
| | | S | SMOKE | LF1 | 12V 0.34W INCANDESCENT LAMP (80,000 HRS. RATED LIFE) | | |
| | | | | | USE CLEAR LENS WITH LEDS | | OR SPECIFY OTHER SPACING |

EXAMPLE

| | | | |
|----------|---|-----|----|
| LF 700 A | C | LF1 | 12 |
|----------|---|-----|----|

FILL OUT BELOW FOR SUBMITTAL

| | | | |
|--|--|--|--|
| | | | |
|--|--|--|--|

| | |
|----------------------------|-----------------------|
| PROJECT NAME | CONTRACTOR |
| FIXTURE SCHED. TYPE | DISTRIBUTOR |
| SPECIFIER | REPRESENTATIVE |



visit us at :
www.celestiallighting.com
e-mail :
info@celestiallighting.com

14009 Dinard Ave.
Santa Fe Springs,
CA 90670

PH (562)•802•8811
(800)•233•3563
FX (562)•802•2882